



HEAT DESIGN CAUSEWAY RANGE OF BOILER STOVES

Installation and Operating Instructions

Please hand these instructions to the stove user when the installation is complete. Leave the system ready for operation and instruct the user in the correct use of the appliance and operation of controls.

Installation – Must be installed by a qualified plumber or suitably qualified fitter

Technical Specifications.

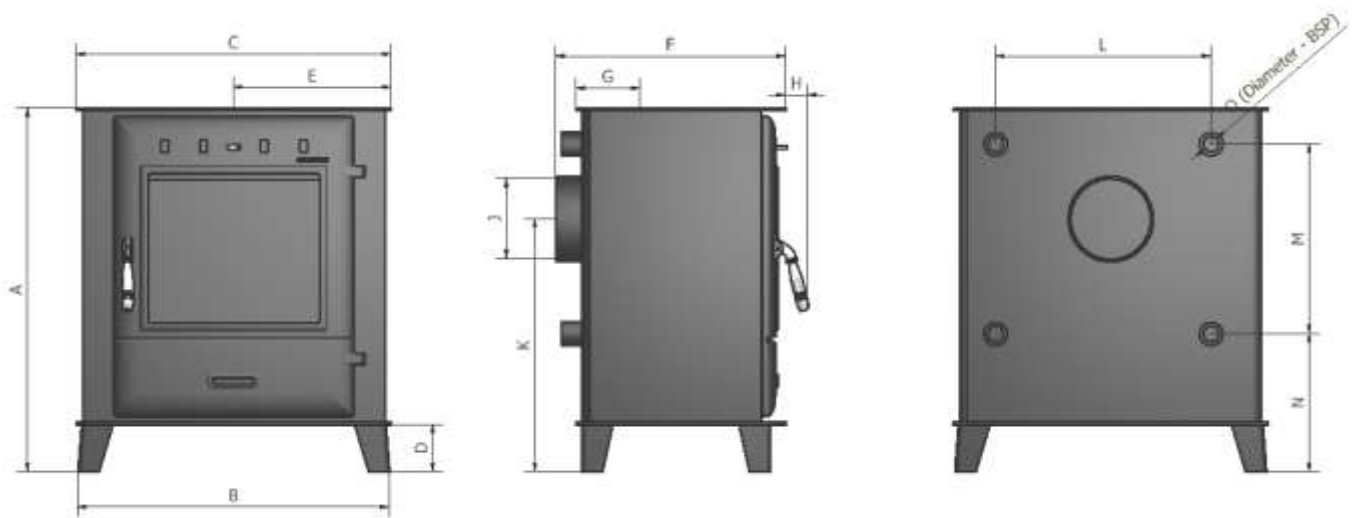

Fig 1 – Causeway 16 and Causeway 25 boiler stove dimensions

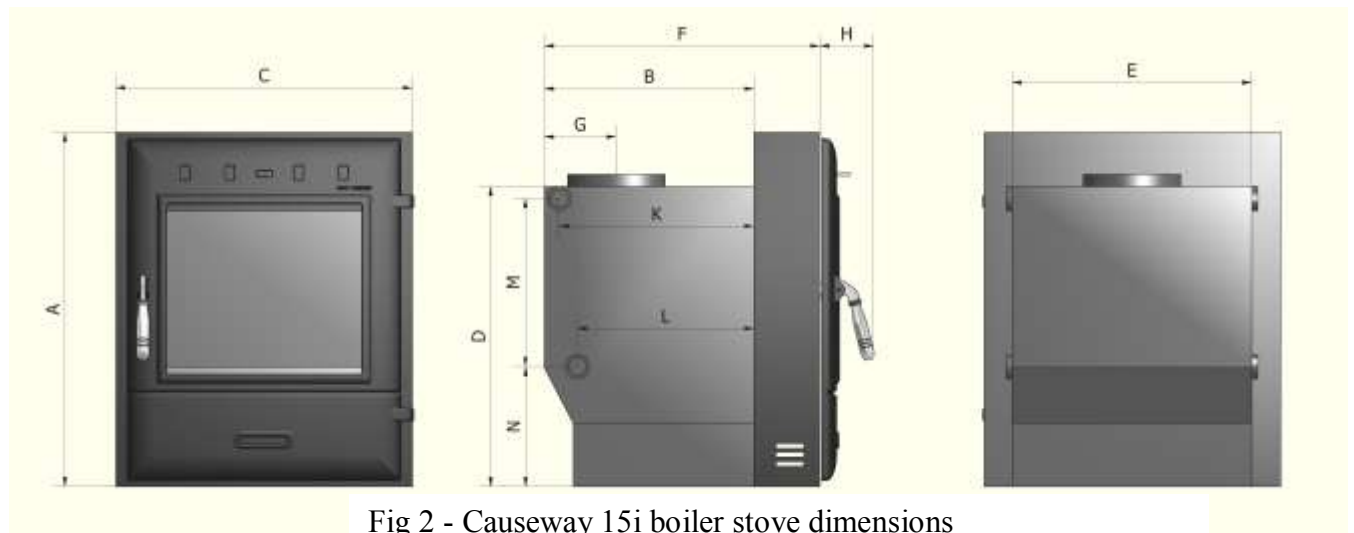

Fig 2 - Causeway 15i boiler stove dimensions

Main Dimensions	A	B	C	D	E	F	G	H	J	K	L	M	N	O
Causeway 16	700	575	600	90	300	455	125	50	6"	480	450	435	250	1"
Causeway 25	730	700	705	125	352	525	160	50	6"	600	520	425	280	1"
Causeway 15i	595	355	500	540	400	120	120	80	6"	335	305	330	190	1"

Technical Specifications		Causeway 16	Causeway 25	Causeway 15i
Total Heat Output	kW	16	25.4	15.1
Output to Water	kW	11.1	18.1	11.8
Output to room	kW	4.9	7.3	3.3
Efficiency	%	75	73.5	73.5
Refuel Period	hr	1	1	1
Safe Distance to Combustibles -Sides	mm	100	100	350
Safe Distance to Combustibles -Top	mm	200	200	550
Flue Outlet Size	Inch	6"	6"	6"
Maximum Boiler Operating Pressure	bar	1.4	1.4	1.4

Assembly Instructions

PLEASE READ THESE INSTRUCTIONS CAREFULLY

It is strongly recommended that this stove is fitted to your heating system by a knowledgeable, experienced and suitably qualified (Hetas or equivalent) plumber or Heating Engineer with experience in fitting boiler stoves. Heat Design cannot accept responsibility for any fault arising through incorrect installation.

Your Heat Design stove comes packed in a cardboard box on a pallet



Fig 3 – Packaging

Carefully remove the straps and box and carefully lift off pallet



Fig 4 – Remove all packaging



Fig 5 Causeway 16 boiler stove components



Fig 6 Causeway 25 boiler stove components



Fig 7 Causeway 15i boiler stove components

Remove the packaging around the stove and, upon opening the door remove contents as shown above

To fit the Collar

The Causeway 16 and Causeway 25 stoves come with the blanking plate already fitted to the top of the stoves. If the stove is to be flued from the back fit the collar to the back of the stove using the two long screws, washers and nuts provided. If the stove is to be flued from the top please remove the blanking plate from the top of the stove and fit to the back and then fit the flue collar to the top of the stove using the screws, washers and nuts provided. There is no need to fit a flue collar to the Causeway insert stove.

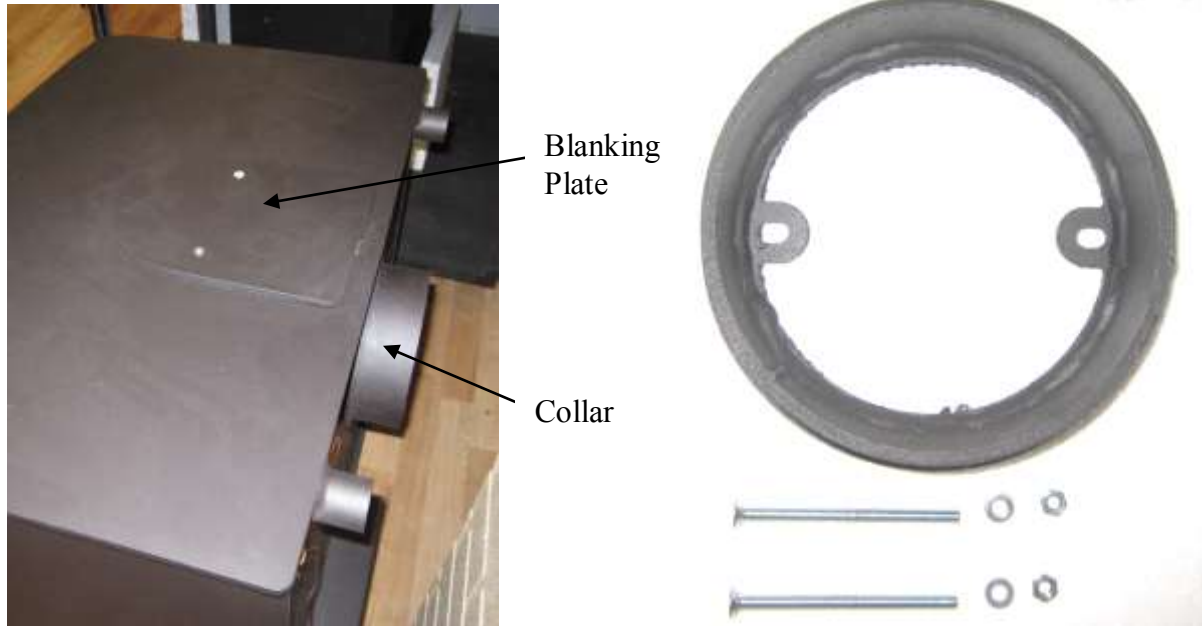

Fig 9
Collar
and
fixings

Fig 8 Blanking plate and collar

To fit the Baffle

Insert the baffle as shown in fig 10 with the chamfers to the bottom and back of the stove and ensuring that the bottom of the baffle is sitting on the baffle angles and hinge the baffle forward so that it sits on top of the internal waterway. The handle of the baffle should be visible as shown.



Fig 10 - Insert baffle with chamfers down



Fig 11 - Sit baffle on baffle angle and hinge forward

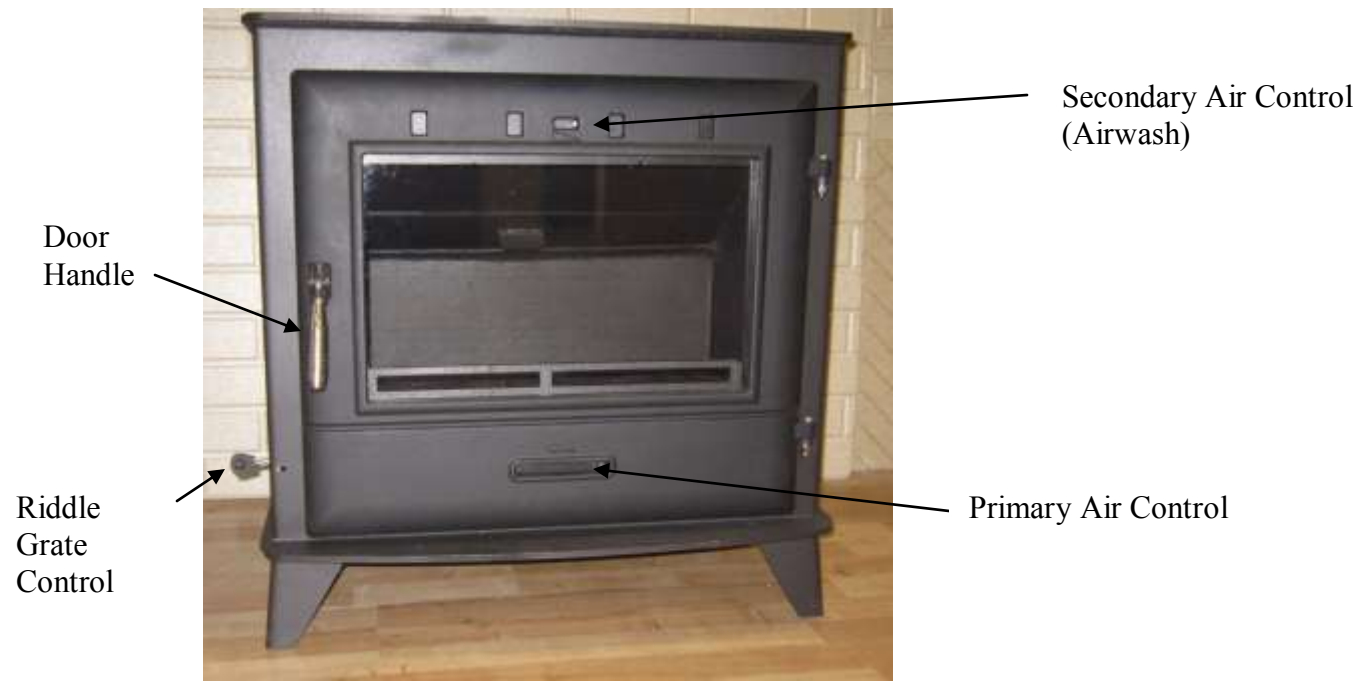

Fig 12 Stove Controls

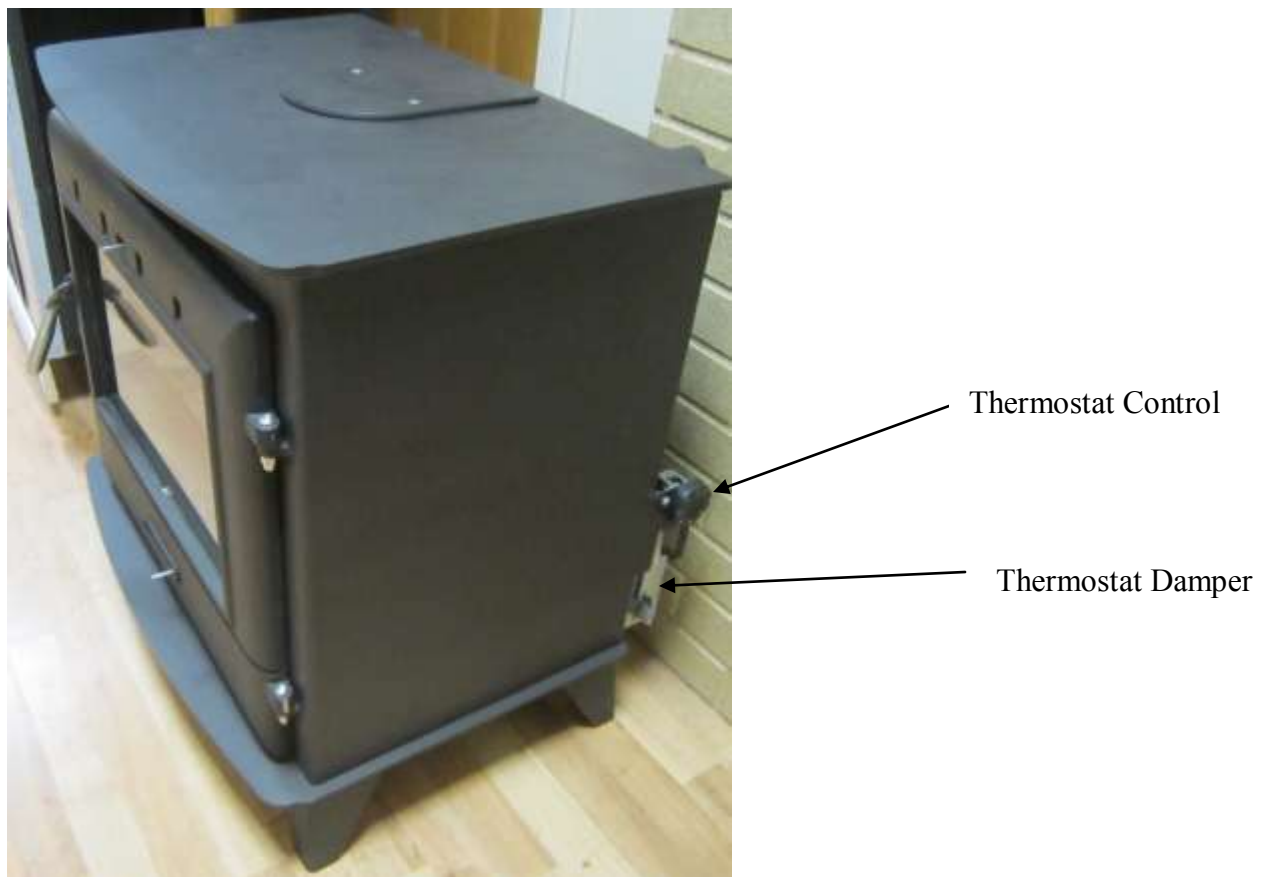

Fig 13 Thermostat

Installation Instructions

READ THESE INSTRUCTIONS CAREFULLY BEFORE INSTALLATION

It is very important to understand the requirements of the National Building Regulations (England and Wales – Document J / Scotland - Part F/Document J (Republic of Ireland only) and standards BS 8303, BS 6461, BS 7566, along with any local regulations and working practices that may apply. Should any conflict occur between these instructions and these regulations then the regulations must apply.

Health and Safety Precautions

Works must be carried out with care to meet the requirements of Health and Safety (Health and Safety at Work Act 1974) and comply with the Health and Safety rules contained therein, and any new regulations introduced during the lifetime of these instructions.

Handling

Adequate facilities must be available for unloading and site handling.

Fire Cement

Some types of fire cement are caustic and should not be allowed to come into contact with the skin. In case of contact, wash immediately with plenty of water.

Asbestos

This stove contains no asbestos. If there is a possibility of disturbing any asbestos in the course of installation then please seek specialist guidance and use appropriate protective equipment.

Metal Parts

When installing or servicing this stove, care should be taken to avoid the possibility of personal injury.

Please note:

Any white deposits on the stove joints are caused by humidity reacting with the joint sealant. These deposits may be brushed off and, if necessary, blackened with a proprietary stove polish.

Important Chimney Warning

This stove must not be installed into a chimney that serves any other heating appliance.

Extractor Fan Warning

There must not be an extractor fan fitted in the same room as the stove as this can cause the stove to emit fumes into the room.

Cleaning and Chimney Sweeping

The appliance, flue & chimney must be cleaned and checked internally and externally regularly in use and especially after a period on disuse (e.g. after summer). Lift down the baffle regularly to check for build-up of soot or debris on the top from the flue pipe. Remove the baffle and check the flue spigot and connector is fully clear at regular intervals. The chimney and flue connector must be swept at least annually, more often when used with sooty fuels or damp wood. Any loose, broken or leaking joints or flue ways MUST be repaired immediately.

Fuels

Only use recommended fuels. The appliance can be damaged by burning petroleum coke, liquid fuels or general rubbish and this will invalidate your warranty and risk your personal safety. The appliance must not be used as a rubbish incinerator.

Maintenance Annual checking and servicing of the appliance and flue by a competent engineer is recommended

Important Warning

This stove must not be installed into a chimney that serves any other heating appliance.

No purpose provided ventilation is normally required for stoves rated under 5KW. However for newer build properties or properties that have been modified so that the design air permeability is less than $5\text{m}^3/\text{h.m}^2$ a permanent ventilator will need to be fitted. Approved document J of the building Regulations gives more detailed information. For each KW above 5KW, 550 sq mm of fixed ventilation is required – i.e. a stove rated at 8KW would require $3 \times 550 \text{ sq mm} = 1650 \text{ sq mm}$ of fixed ventilation. If more than one appliance is installed in the same room, the ventilation requirements for each appliance must be added together.

There must not be an extractor fan fitted in the same room as the stove as this can cause the stove to emit fumes into the room.

Installation

Thermostat

A thermostat control is fitted to your boiler which is used to automatically regulate the water output temperature and prevent water overheating in the boiler. It is recommended to initially set the thermostat to half open and adjust as deemed necessary after the first few times of use to achieve the desired output from the stove.

Chimney

The chimney height and the position of the chimney terminal should conform to Building Regulations. Check that the chimney is in good condition, dry, free from cracks and obstructions. The diameter of the flue should not be less than 150mm and not more than 200mm. If any of these requirements are not met, the chimney should be lined by a suitable method. The chimney must be swept before connection to the stove.

Where the chimney is believed to have previously served an open fire installation, it is possible that the higher flue gas temperature from the stove may loosen deposits that were previously firmly adhered, with the consequent risk of flue blockage. It is therefore recommended that the chimney be swept a second time within a month of regular use after installation. If you have any doubts about the suitability of your chimney, consult your local dealer/stockist.

If there is no existing chimney then either a prefabricated block chimney or a twin-walled insulated stainless steel flue to BS 1856-1 can be used. These chimneys must be fitted in accordance with the manufacturer's instructions and also please refer to the current issues of British Standards BS EN 15287-1:2007 for design, installation and commissioning of chimneys.

Electrical Connection

The installation of any electrical services during the installation of this boiler and the associated heating system must be carried out by a registered competent electrician in accordance with the requirements of the latest issue of BS7671.

Flue Draught

A flue draught of minimum 1.2mm to a maximum 2.5mm water gauge is required for satisfactory appliance performance. The flue draught should be checked under fire at high output and, if it exceeds the recommended maximum, a draught stabiliser must be fitted so that the rate of burning can be controlled and to prevent overfiring.

Connection to the Chimney

An existing fireplace opening can be bricked up or sealed with a register plate. A short length of flue pipe of a minimum 150mm internal diameter may then be used to connect the stove to the chimney. This flue pipe should conform to Building Regulations. Ensure that the pipe end is no closer than 76mm to the side or rear chimney walls.

Ideally, the old fireplace should be filled in so that there is a smooth streamlined entry into the flueway. The length of any horizontal run of flue pipe must not exceed 150mm.

It is essential that all connections between the stove and chimney-flue are sealed and made airtight. This appliance is not suitable for installation in a shared flue system.

Both the chimney and flue pipe must be accessible for cleaning and if ANY parts of the chimney cannot be reached through the stove (with baffle removed), a soot door must be fitted in a suitable position to enable this to be done.

Material Clearances

The stove can be recessed in a suitable sized fireplace but a permanent free air gap of at least 150mm must be left around the sides and top and at least 50mm at the back of the stove to obtain maximum heat output and for access to the rear of the stove.

All non-combustible walls closer than 400mm to the stove should be at least 75mm thick. In all instances the back wall of the fireplace recess and the hearth should be made of non-combustible material. Allow an apron of at least 300mm at the front of the stove and 150mm on either side.

The hearth on which the stove is to be placed should not be less than 125mm thick and should be in accordance with the current building regulations.

Care should be taken to level the stove using the adjusting screws in the feet.

The appliance shall be installed on a floor with adequate load-bearing capacity. If the existing construction does not meet this prerequisite, suitable measures (e.g. load disturbing plate) should be taken to achieve it.

Safety Distances from Combustible Surfaces:

See Technical Specifications.

Boiler Connection

1. CONNECTION TO EXISTING HEATING SYSTEM - STOVE AS SECONDARY HEAT SOURCE

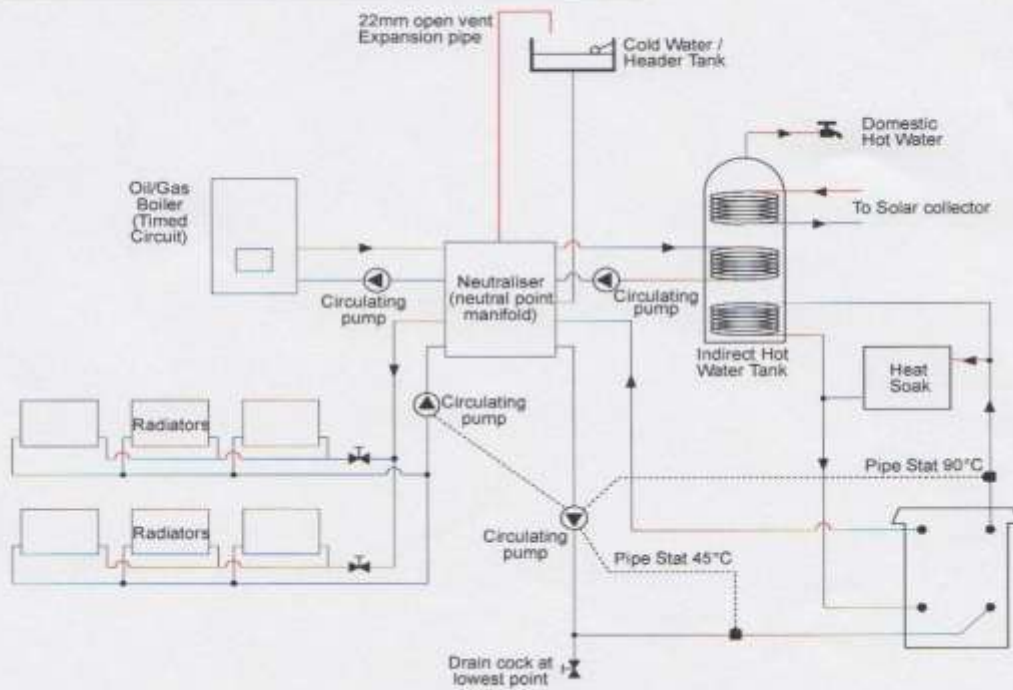

2. CENTRAL HEATING & HOT WATER (INDIRECT LINK UP) USING 4 TAPPINGS - STOVE AS PRIMARY HEAT SOURCE

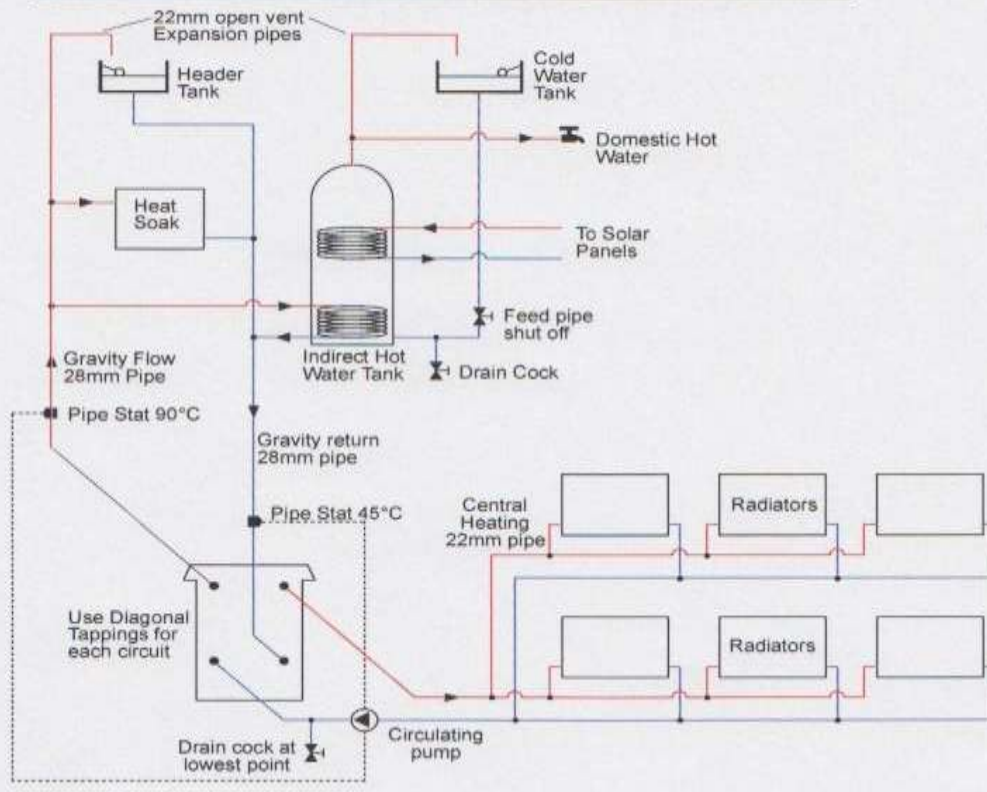

3. CENTRAL HEATING & HOT WATER (INDIRECT LINK UP) USING 3 TAPPINGS - STOVE AS PRIMARY HEAT SOURCE

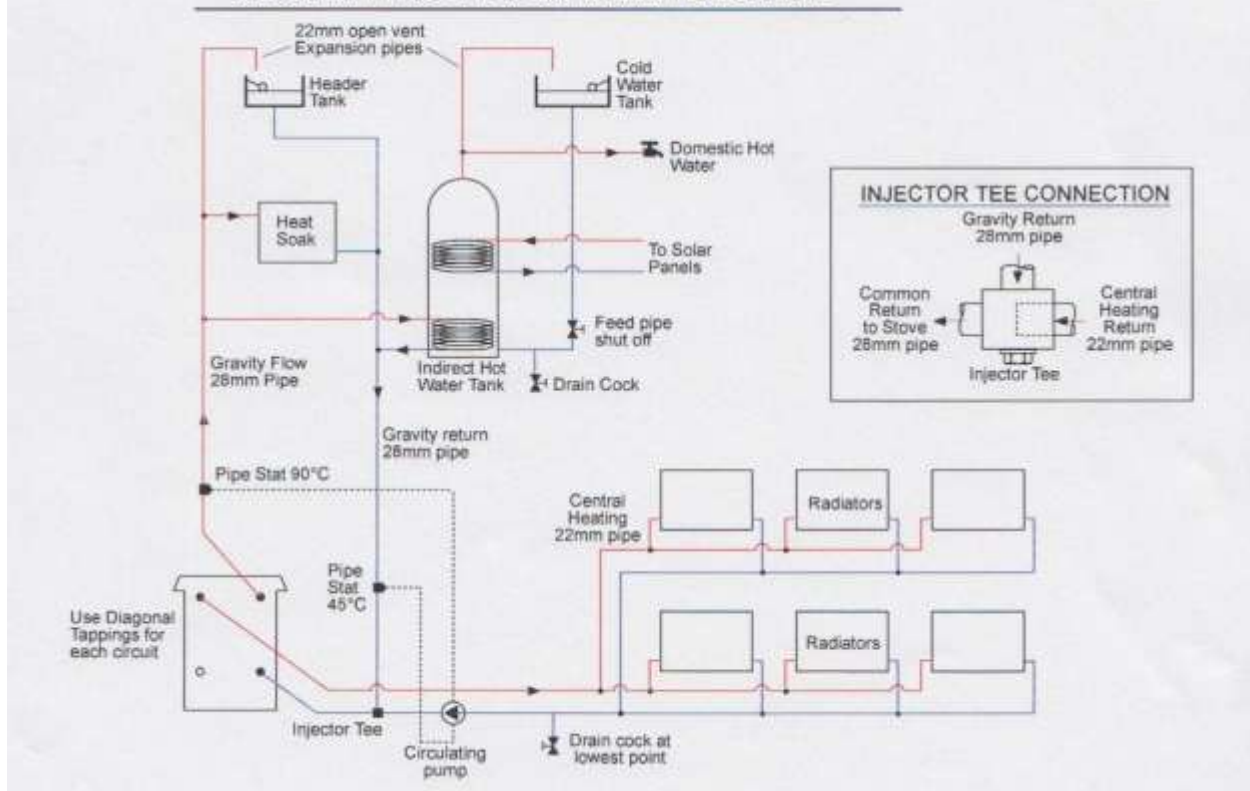

It is strongly recommended that this stove is fitted to your heating system by a knowledgeable, experienced and suitably qualified (Hetas or equivalent) plumber or Heating Engineer with experience in fitting boiler stoves. If fitted incorrectly it could result in serious damage to your home heating system. Plumbing should be carried out in accordance with Relevant Building Regulations and safe practices. The manufacturers cannot be held responsible for any losses due to incorrect specification or connection of the heating system.

Gravity Circuit

Do Not – Under any circumstances connect the stove to a sealed (pressurised) heating system or an unvented HW cylinder

Do Not – Link the stove into a heating or hot water system with an existing boiler without the use of suitable equipment such as a neutralizer. When fitting this type of system the neutralizer manufacturer's instructions must be followed.

Do – Fit an open cold feed and header expansion tank with separate cold feed and vent pipes. The cold feed and vent pipes must be unvalved. The open vent pipe should have a diameter of 22mm and rise continuously from the boiler.

The gravity circuit should connect to a domestic indirect hot water cylinder of minimum 135lt capacity, using 28mm flow and return pipes, rising continuously from the boiler to the cylinder. Any nominally horizontal runs of gravity pipework should slope upwards at not less than 1:30. The base of the hot water cylinder should be located at least 150mm above the top of the stove. The gravity circuit must not contain any shut off valves and should be fully lagged to minimise heat loss. The pipes should not exceed 7.8 meters (25ft) in length to/from the cylinder. In general, the shorter the run of pipework the less heat loss and the more efficient the water heating.

A heat soak radiator of at least 2kW must be used on the same gravity circuit, positioned above the stove. This is used to dissipate heat when the central heating is switched off or the HW cylinder is fully heated.

Link Up:

On heating and hot water installations, a semi-pumped system should be used to the central heating system with gravity circulation to the hot water cylinder. For optimum performance of the boiler we recommend that all 4 tappings are used when using separate gravity and pumped heating loops. The flow and return pipes should be taken from diagonally opposite sides of boiler.

Injector Tee:

If only two tappings are used on a common flow system, they should be taken diagonally opposite and the remaining tappings should be plugged. An injector Tee should be fitted to join the gravity feed and central heating circuits back to the stove, which should be situated as close to the stove as possible. The tee connection encourages the stable flow of water through both circuits and prevents priority being given to the stronger flow, typically the pumped circuit.

Pipe Thermostats

A HIGH LIMIT thermostat should be fitted to the gravity flow pipe close to the boiler and set at 90°C. This should override any pump control, switching the pump on and dissipating any excess heat around the radiator circuit. To prevent boiler corrosion due to condensation it is necessary to maintain the return water temperature above 45°C. This can be achieved by the use of a LOWLIMIT thermostat on the return pipe from the hot water cylinder, close to the boiler. The thermostat should make on temperature rise, preventing the circulating pump from operating until the gravity circuit is up to temperature.

Commissioning and Handover

Upon completion of the installation, allow a suitable period of time for any fire cement and mortar to dry out. A small fire may then be lit and checked to ensure the smoke and fumes are taken from the stove up the chimney and emitted safely to atmosphere. Do not run the stove at full output for at least 3 – 4 days.

On completion of the installation and commissioning, ensure that the operating instructions and operating tools for the stove are left with the customer. Ensure to advise the customer on the correct use of the appliance with the fuels likely to be used on the stove and warn them to use only the recommended fuels for the stove.

Advise the user on what to do should smoke or fumes be emitted from the stove. The user should use a suitable fireguard in the presence of children, aged and/or infirm persons.

All connections to the boiler should be checked to ensure there are no leaks during operation and that the flow and return water connections are working properly. The stove should be fired up initially by the Plumber / Heating Engineer to ensure that it is operating safely with the rest of the heating system.

Operating Instructions

This appliance is not suitable for use in a shared flue.
This appliance should not be operated with the doors open.

Aerosol Sprays

Do not use an aerosol spray on or near the stove when it is alight.

Air Controls

This stove has been designed to burn clean and efficient. If used correctly this stove will burn far more efficiently than normal with the obvious notable features of CLEAN GLASS. Never clean glass when stove is hot. Always use stove glass cleaner which is available from your stove retailer.

However, for this product to work properly it must be used correctly.
It is essential that the stove has an adequate air supply for combustion and ventilation.

The primary and secondary air inlets must be kept clear from obstruction.

Note:

The secondary air control is open when pushed to the Left.

Warning! This appliance will be hot when
In operation and due care should be taken
When operating the controls.

Air Controls

Primary Air

Primary air is controlled via a sliding control on the bottom of the door.
This provides a conventional air draught to the bed of the fire. The primary air intakes can be adjusted to give the best possible results when burning different fuels.

Secondary Air

The cast iron stove is fitted with a sophisticated “air wash” system. This secondary air supply to the stove is controlled through a slider assembly located at the top of the stove.

Multifuel Grate

Your Stove is fitted with a rotary style grate, which is operated from the front of the stove via a riddle rod. Use the “Hook” end of tool to operate the riddling system. This rotary grate is located in the centre of a cast iron flat bed with suitable air slots that assist the burning of most fuels. It is important to use the rotary grate to de-ash regularly, to ensure that the primary airflow is not impeded, as a build-up of ash can damage the cast iron bed.

Ashpan

It is essential that you empty the steel ash pan every day. Use the thick end of tool to hook onto and lift the ash pan out of the stove. DO NOT allow ash to build up underneath the bed as this may cause damage to the grate.

Notes on Wood burning

With a full load of wood, the stove will need to be refuelled approximately every 1 hour. Wood can be stacked higher in the stove than solid mineral fuel but care must be taken that logs do not touch the baffle.

Wood burns most efficiently with the primary air controls closed and the secondary control partially open. Moving the secondary control will control the burn rate of the stove.

Note – primary and secondary air is needed to light the stove, see section entitled ‘Lighting the Stove’.

Wood burns best on a bed of ash and it is therefore only necessary to remove surplus ash from the stove occasionally.

Burn only dry, well-seasoned wood, which should have been cut, split and stacked for at least 12 months, with free air movement around the sides of the stack to enable it to dry out. Burning wet or unseasoned wood will create tar deposits in the stove and chimney and will not produce a satisfactory heat output. Do not use liquid fuels in this appliance.

Size of Fuel

Log Length

Maximum Log Lengths	
Causeway 16 Boiler Stove	440mm
Causeway 16 Boiler Stove	500mm
Causeway 15i Boiler Stove	440mm

+-

Lighting the Stove

We recommend that you have two or three small fires before you operate your stove to its maximum heat output. This is to allow the paint to cure in steadily and to give a long service life of the paint finish. During this curing in process you may notice an unpleasant smell. It is non-toxic, but for your comfort we would suggest that during this period you leave all doors and windows open.

Ensure the Primary and secondary air controls are fully open and place some dry paper or firelighters on the grate. Then place a handful of dry kindling on top. Light the fire at the base leaving the primary and secondary air open. Allow the fuel to reach a steady glow (approximately ten minutes) and then add a little more fuel (approximately two or three small logs). Once you have a good fire established across the grate bed, further fuel can be added as required and the primary air controls can be shut completely.

Refuelling

It is best to refuel little and often, rather than in large pieces. When possible refuel the stove before the bed has gone too low. Open the primary air control a little and add the fuel. Allow the fuel to burn for a few minutes until the fire is well established before closing the primary air once again. This refuelling procedure will ensure that smoke emission is kept to a minimum.

Shutting Down

In order to shut down the stove, close the primary air control, then close the secondary air slider by moving the handle all the way to the left. If the controls are left in this position, the fire will be starved of air and will go out. If you want to revive the fire it is recommended that the primary air control is opened first, and then open the secondary air slider. Please note that the stove cannot be shutdown in this manner when the secondary air stop is fitted as this would produce smoke.

Warning! - The stove will remain hot for a considerable time after the fire has been extinguished.

Notes:

Warning! - Petroleum coke fuels or household waste must not be burnt on this appliance. Should any difficulties arise over fuel quality or suitability, consult your local approved coal merchant.

Maintenance

Inspect the inside of the firebox and above the baffle plate every week during use. See chimney cleaning section in warnings section of Installation Instructions. Only use manufacturers recommended replacement parts on the appliance

Seasonal Use

Remove the baffle and inspect the inside of the stove and the flue ways and ensure they are 100% clear after a period of disuse, for example if the stove is not used during the warmer periods of the year. Also set the air controls to 50% to keep the appliance ventilated and stop the build-up of any moisture inside.

Frozen System

If there is any possibility that the water system may be frozen do not attempt to light the stove until you are certain there is no ice in the system possibly causing a blockage.

Safety Notes for your guidance

FIRES CAN BE DANGEROUS – Always use a fireguard in the presence of children, the elderly or the infirm.

DO NOT OVERFIRE – it is possible to fire the stove beyond its design capacity, this could damage the stove, so watch for signs of overfiring – if any part of the stove starts to glow red, the fire is in an overfire situation and the controls should be adjusted accordingly. Never leave the stove unattended for long periods without first adjusting the controls to a safe setting – careful air supply control should be exercised at all times.

Any unauthorised modifications of this appliance will render the guarantee null and void and could be potentially dangerous. Replacement parts should only be sourced from Heat Design approved dealers

CO ALARMS

Building Regulations require that whenever a new or replacement fixed solid fuel or wood/biomass appliance is installed in a dwelling a carbon monoxide alarm must be fitted in the same room as the appliance. Further guidance on the installation of the carbon monoxide alarm is available in BS EN 50292:2002 and from the alarm manufacturer's instructions.

Provision of an alarm must not be considered a substitute for either installing the appliance correctly or ensuring regular servicing and maintenance of the appliance and chimney system.

Your installer should have fitted a CO alarm in the same room as the appliance. If the alarm sounds unexpectedly, follow the instructions given under "Warning Note" below.

WARNING NOTE – FUME EMISSION

Properly installed, operated and maintained this appliance will not emit fumes into the dwelling. Occasional fumes from de-ashing and refuelling may occur. However, persistent fume emission is potentially dangerous and must not be tolerated.

If fume emission does persist, then the following immediate action should be taken: -

1. Open doors and windows to ventilate room and then leave the premises
2. Let the fire out
3. Check for flue or chimney blockage and clean if required
4. Do not attempt to re-light the fire until the cause of the fume emission has been identified and corrected. If necessary seek expert advice.

The most common cause of fume emission is flueway or chimney blockage. For your own safety these must be kept clean at all times.

IN THE EVENT OF A CHIMNEY FIRE

- Raise the alarm to let others in the house know.
- Call the Fire Brigade
- Reduce the appliance-burning rate by closing all air controls.
- Move furniture and rugs away from the fireplace and remove any nearby ornaments.
- Place a fireguard or spark guard in front of the stove.
- Feel the chimneybreast for sign of excessive heat.

If the wall is becoming hot, move the furniture away. Ensure that the Fire Brigade can gain access to your roof space in order to check this area for signs of fire spread.

Frequently Asked Questions

1 Do stoves require a chimney?

All of our multi fuel and wood burning stoves require a suitable chimney or professionally installed flue system.

2 How do I clean the chimney?

You will require a chimney sweep to clean the chimney. It is best to provide a dedicated chimney cleaning access door when installing the flue of the stove.

3 Who should install my stove?

Heat Design want you to enjoy the maximum performance from your Stove products. To ensure this, it is essential that they are installed correctly.

We strongly recommend that your Heat Design Stove products are installed by a qualified plumber or suitably qualified person.

4 How do I regulate the heat output?

Each stove will have spin valves, which will allow you to easily regulate the heat output.

5 What warranty policy do I get?

Heat Design Stoves will replace, free of charge, any working part that fails (under normal operating conditions) within 12 months of purchase. Consumables such as glass or stove rope are not guaranteed.

A call out charge will apply if our engineer attends any stove problem that is not related to product failure.

6 Where can I get spare parts?

Your local Heat Design Stove retailer will be pleased to supply spare parts and to provide any other information you require.

7 Can the doors be left open while burning?

For safety and heat efficiency the doors should remain closed at all times.

8 Why is the stove smoking when lit?

A smoking stove can be caused by a flue with back draught problems. A qualified fitter should complete a smoke test prior to fitting the stove to ascertain the integrity of the flue.

9 Why should I "Run in" my stove?

To begin, light a series of small fires over a period of a few days to allow the paint finish to cure. The stove is finished with a heat resistant paint and this can be cleaned with a soft brush. Do not clean whilst the stove is hot; wait until it has cooled down. The finish can be renovated with proprietary stove paint

If the stove is not "run in" correctly, this may cause the paint to discolour and flake.

10 What is Over Firing?

Your stove should never be used in a manner to cause over firing. Over firing can be caused by over loading the stove with fuel, and with primary controls open. If any part of stove glows "red" your stove is over firing and your draught control should be adjusted to restrict airflow to stove. Over firing can cause permanent damage to the appliance which is not covered by warranty.

Spare Parts

	Component	Causeway 16 Boiler	Causeway 25 Boiler	Causeway 15i Boiler
01	Door Glass	Y1WX01A	Y1WXF25B01A	Y1WX01A
02	Glass Brackets and Screws	Y1WXF02A	Y1WXF25B02A	Y1WXF02A
03	Door Handle assembly	Y1WXB03A	Y1WXB03A	Y1WXB03A
04	Coalcatcher	Y1WXF16B04A	Y1WXF25B04A	Y1WXF15I04A
08	Riddle Grate	Y1HDD09E	Y1HDD10E	Y1HDD09E
09	Grate for Riddle Grate	Y1WXF16B12A	Y1WXF25B12A	Y1WXI16B12A
12	Riddle Grate Handle	Y1HDF06D16E	Y1HDF06X15E	Y1HDF06D15E
13	Riddle Grate Bar	Y1WXF16B16A	Y1WXF16B16A	Y1WXI15B16A
16	Baffle Plate	Y1WXF16B19A	Y1WXF25B19A	Y1WXI15B19A
18	Airwash slider plates	Y1WXF021A	Y1WXF25B21A	Y1WXF021A
19	Airwash Housing	Y1WXF019A	Y1WXF25B22A	Y1WXF019A
22	Ashpan	Y1WXF16B28A	Y1WXF25B28A	Y1WXI15B28A
24	Stove Tool	Y1WX30A	Y1WX30A	Y1WX30A
25	Ashpan Tool	Y1WX31A	Y1WX31A	Y1WX31A
26	Door	Y1WX32A	Y1WXF25B32A	Y1WX32A
27	Primary Air Control including handle	Y1WX33A	Y1WXF25B33A	Y1WX33A
42	Airwash Handle	Y1WX49A	Y1WX49A	Y1WX49A
44	Door Hinge/Pin	Y1WX51A	Y1WX51A	Y1WX51A
53	Door Latch roller	Y1WX61A	Y1WX61A	Y1WX61A
64	Thermostat	Y1WX72A	Y1WX72A	Y1WX72A
65	thermostat knob	Y1WX73A	Y1WX73A	Y1WX73A

Grate Assembly

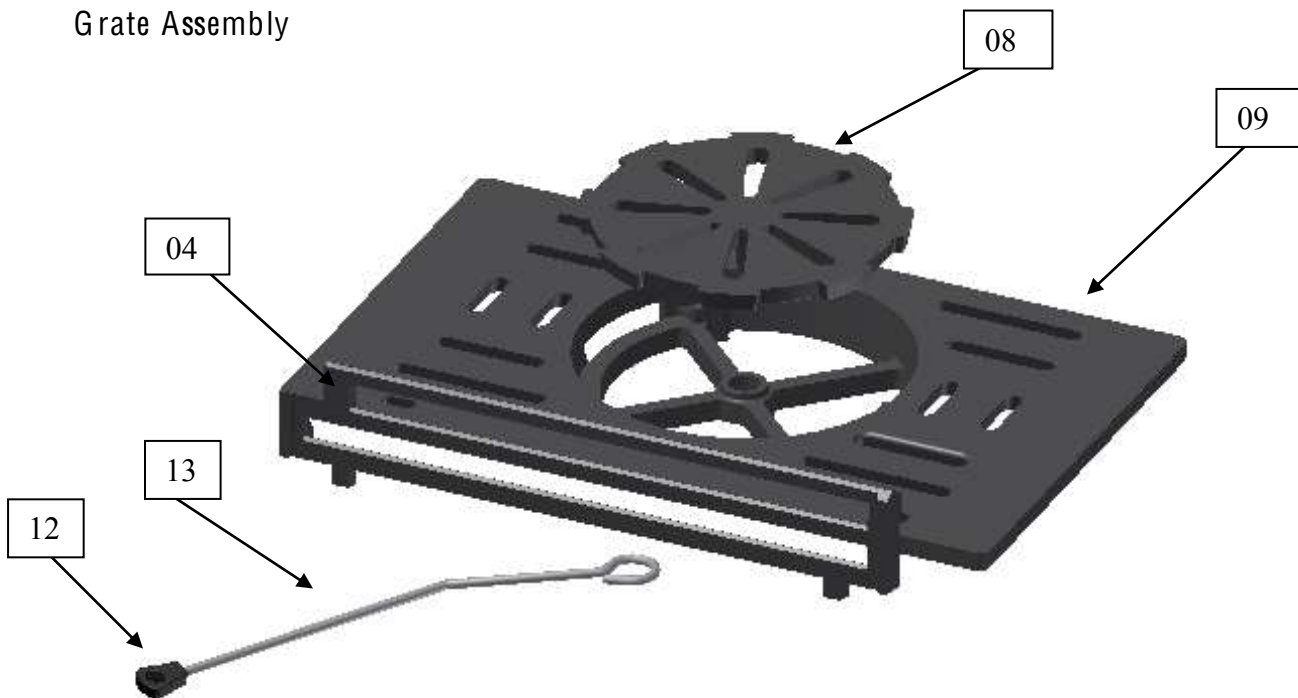

*Heat Design
30 – 60 Hawthorn Road
Western Industrial Estate
Dublin 12
Ireland*

Revised 20-06-13